

# Finding Hidden Problems Using Agilent's Deep-Memory Oscilloscope: How IBM Solved a Mystery

Customer Success Story

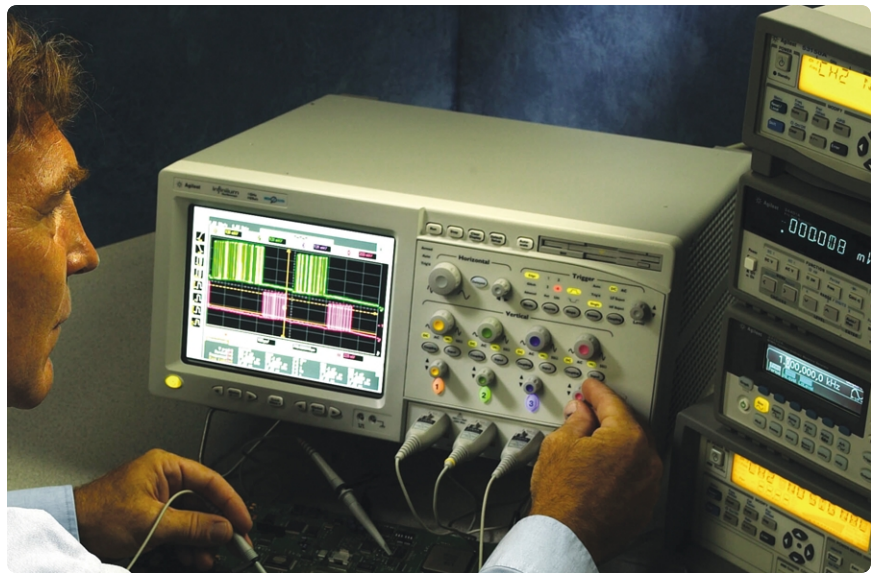

**Customer:**  
**Mark Andresen, Advisory Engineer**  
**IBM Server Group**  
**Raleigh, North Carolina**

## The Challenge

When everything looks right but something is still wrong. Every engineer knows the feeling: As far as you can see, everything is working properly – the right signals are getting to the right places at the right times, the firmware is doing what it's supposed to do, and everything else is in order – and yet the system still doesn't function properly. The situation can drag on for days or weeks,

putting product launches and production schedules in jeopardy while you continue to search for clues.

Mark Andresen, an Advisory Engineer with IBM's Server Group, recently found himself in just such a scenario. One of the company's PCI interface card products was mysteriously failing on the production line, but the problem affected only some units and not others.



**Agilent Technologies**

## Starting the Investigation

Of course, any time a you're in danger of stopping a production line, it's a major financial issue and customer satisfaction concern, so Mark jumped into action. His initial investigation narrowed the problem to cards using flash memory modules from one particular vendor; identical cards using flash modules from three other vendors worked perfectly.

The logic analyzer screen in Figure 1 shows key control signals for the flash module during the start-up sequence. (Figure 2 shows the flash module and the chip-control signals generated by the CPU, and Table 1 explains the function of each relevant signal.) By the time the active-low reset signal (RP\_N) was pulled high (roughly 110 milliseconds into the sequence), the 3.3 V power signal is active and confirmed by the voltage supervisor signal (PF\_3.3 V). At this point, the memory module should have received a chip select pulse and begun generating valid data, but its outputs were still tri-stated and the chip select activity Mark expected was nowhere to be seen.

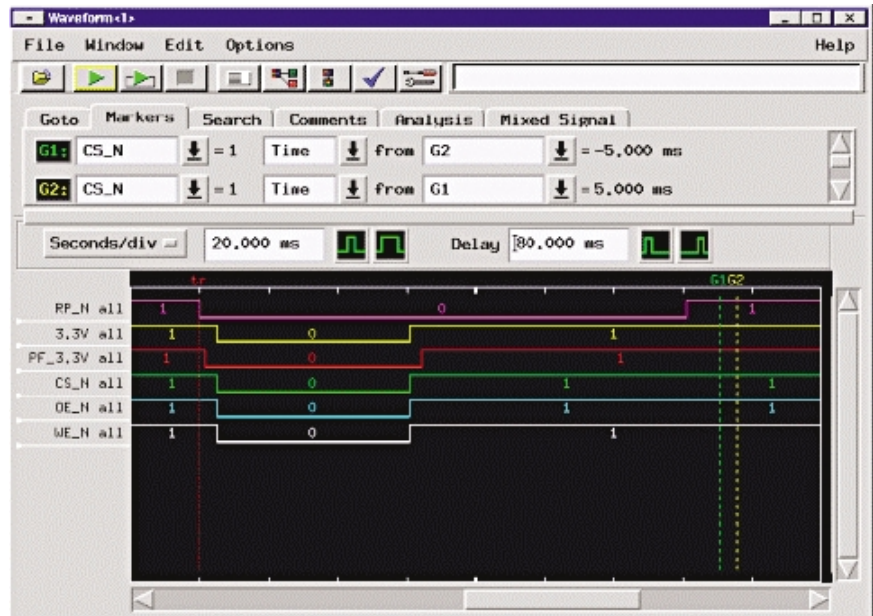

**Figure 1.** The flash memory module was receiving the correct control signals and should have been generating valid data after the reset signal (RP\_N) went inactive, but its output were still tri-stated and the chip select activity Mark expected in the area outlined by the display markers was nowhere to be seen.

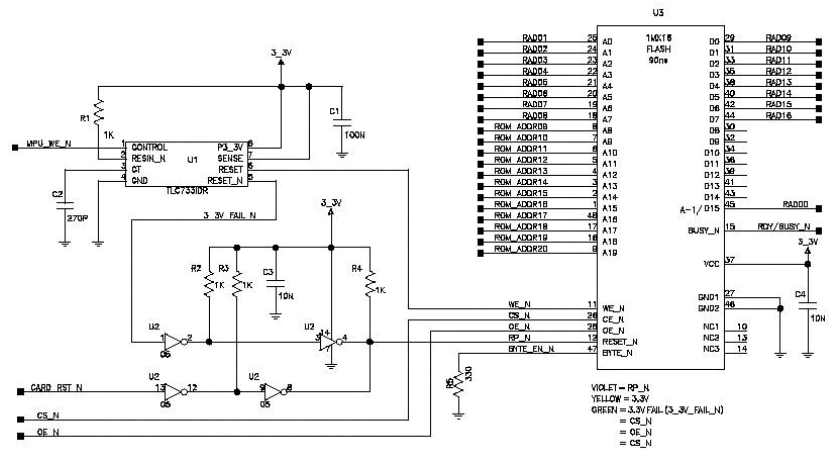

**Figure 2.** Chip-control connections to the flash memory module.

## Analog or Digital Origins?

To study the problem in more detail, Mark needed a way to capture the entire start-up sequence with enough resolution to find fast-moving signals. A key part of the challenge was figuring out whether the problem was analog in nature (e.g., signal integrity issues) or digital (e.g., incorrect commands or hardware timing malfunctions).

It was a classic example of the memory depth-versus-resolution trade-off in both scopes and logic analyzers. In order to capture all the relevant activity in the start-up sequence, Mark had to use a very slow timebase setting on the analyzer. Slow timebase setting will result in less horizontal resolution. At lower resolution, the activity of the chip select may not be visible on the analyzer.

Mark switched to a high-speed, conventional-memory scope (Figure 3), but since it was unclear where and when he needed to trigger, it proved impossible to catch the problem with this approach as well. The scope didn't have deep enough memory to catch the entire 160 ms reset-read cycle with sufficient resolution.

Schematic label	Signal name	Function
RP_N	Flash module reset	Resets flash module; connected to card's master reset circuitry.
Vcc	3.3 V power supply	Provides power to memory module.
3.3 V fail	Voltage supervisor	Monitors supply voltage; driven low when power drops below 5 percent.
CS_N	Chip select	Standard chip select/enable signal; generated directly by the CPU.
OE_N	Output enable	Standard output enable signal; generated directly by the CPU.
WE_N	Write enable	Write enable signal generated by the CPU via a voltage supervisor (U1). Driven high when power falls below 5 percent and supplies a clean rise time at power-on time. U1 turns on at a lower voltage than the Flash to minimize false writes.

**Table1: Chip control signals.**

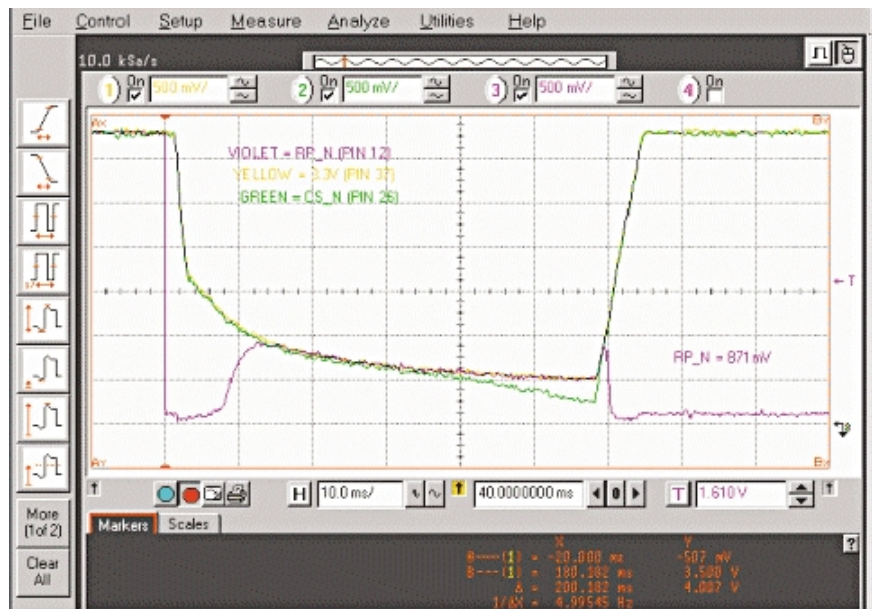

**Figure 3. With a standard high-speed scope, the analog behavior of the signals becomes apparent, but the chip select activity expected after RP\_N went high was nowhere to be seen.**

## Finding the Problem with MegaZoom Deep Memory Scope

Finally, Agilent Infiniium oscilloscope with MegaZoom deep memory uncovered the problem. As Figure 4 shows, the CPU was in fact generating chip select activity shortly (CS\_N) after the reset signal (RP\_N) went inactive high. Now Mark knew the memory module was getting the right commands and the right time. On to the next question: Why wasn't the memory responding?

Because deep memory captured much more data than was actually shown on screen, zooming in for a closer look at the chip select activity was as simple as telling the scope where to look and lowering the /div setting. In Figure 5, Mark zoomed in tightly around the CS\_N spike (upper trace) and set the resolution from 20 ms/div to 4  $\mu$ s/div (lower trace). Not only was the chip select line getting pulsed, but it now became obvious that the CPU was pinging the memory module nearly two dozen times, trying to get it to respond.

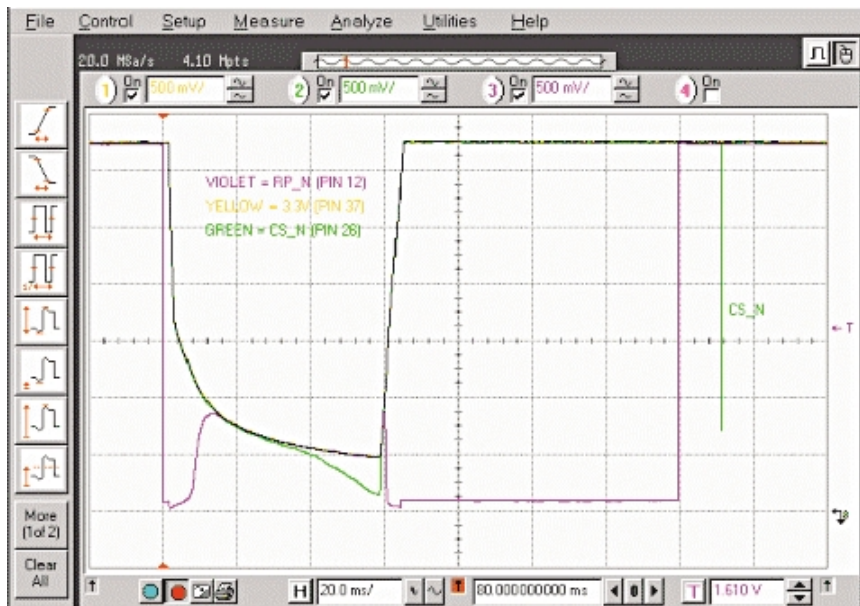

Figure 4. A high-resolution deep memory waveform capture uncovered chip select activity (CS\_N) shortly after the chip reset signal (RP\_N) went inactive high, narrowing the source of the problem to the memory module itself.

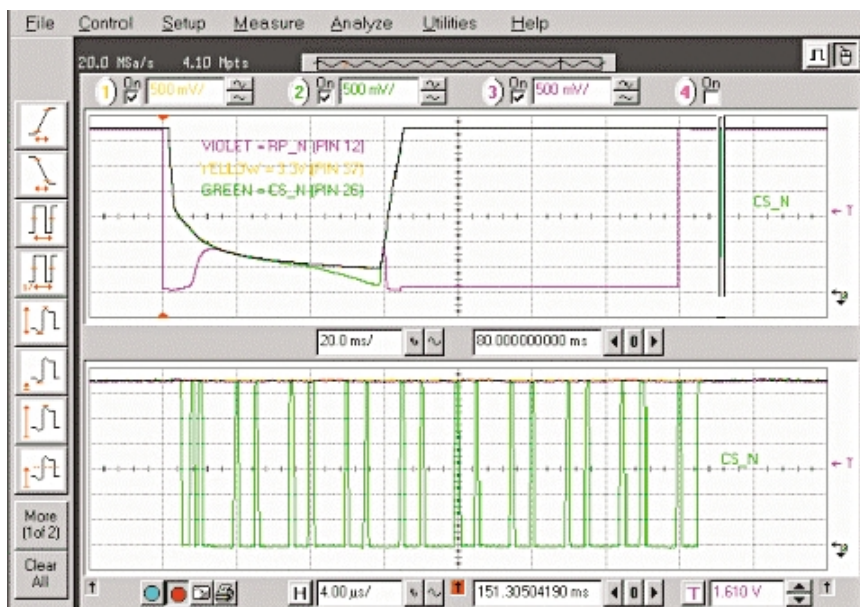

Figure 5. Zooming in on the captured data with 5000X magnification revealed nearly two dozen individual chip select commands. This flurry of chip select activity from the CPU, with no resulting data from the memory module, clearly indicated that the module was hung up.

Convinced that the problem lay with the memory module, Mark turned his attention to the voltage profile of the chip select signal earlier in the reset sequence. Due to some design considerations elsewhere in the system, the power supply level dropped to 1.1 V for a period of roughly 20 ms. Although there was nothing in the chip's specifications that prohibited this situation, the chip got stuck in an indeterminate state whenever this happened and could not be recovered through another reset cycle (RP\_N going low) even when active for over 60 Ms with 3.3 V in specification. Mark solved the problem temporarily by adding a capacitor that prevented the supply line from dropping into this range, thereby allowing the part to reset correctly (Figure 6).

Discussions with the part vendor confirmed that this was a known (but not communicated) problem with the flash chip. If the supply voltage (yellow trace) dropped into the 1.1-1.2 V range and not all the way to 0.0 V, the part would not initialize correctly. The deep-memory scope displayed a more-accurate voltage profile, which the memory vendor was able to use to analyze the part's performance more closely. Fortunately, IBM had been second-sourcing memory modules from three other suppliers, so Mark and his team were able to simply avoid using the faulty part without making any circuit changes.



**Figure 6. With a temporary capacitor added to prevent the 3.3 V from dropping into a range that sent the memory module into an indeterminate state, the module began generating valid data.**

## Applying Deep Memory Technology to Other Measurement Challenges

The unique capabilities of deep memory offer a compelling measurement solution whenever you have high-speed signals interacting with low-speed signals or long data streams, particularly when there are important events spaced far apart in time. In general, deep memory scopes can be helpful in all the following applications:

- Long serial data streams, including Bluetooth baseband, USB, CAN, SPI, I<sup>2</sup>C, Ethernet LAN, and serial HDTV signals.
- Mixed analog and digital designs, including power supply designs, motor drives, PLC design, battery-powered devices, embedded processors, ADC, DAC, and data-acquisition systems.
- Finding details buried in complex waveforms, such as modulated signals and video signals.
- Capturing and analyzing infrequent and unpredictable events, such as glitches, runts, and transients.
- As a substitute for complex triggering; simply edge-trigger on an event and capture everything associated with it, then pan around and zoom in on the details you want to analyze.

The usefulness of deep memory has improved considerably in recent years with fast, responsive displays and transparent operation – solving the two biggest frustrations with traditional deep-memory scopes. The new MegaZoom Infiniium oscilloscope from Agilent Technologies features automatic deep memory that allows maximum sample rates to be available at all times, without requiring users to calculate and then manually set the memory.

The second problem with traditional deep memory oscilloscope is the responsiveness of the display with control changes. When capturing a waveform with the deepest memory selected, the scope can take up to dozens of seconds to respond to a control change. The Infiniium deep memory oscilloscopes use the MegaZoom deep memory architecture to provide instant response to control changes even with the deepest memory on. Instant response to control changes means that the display updates as quickly with up to 16 Mpts memory depths as with 100 kpts memory depths. Figure 7 (next page) shows how MegaZoom scopes deliver this new level of performance.

## Conventional Deep-Memory Scope Architecture

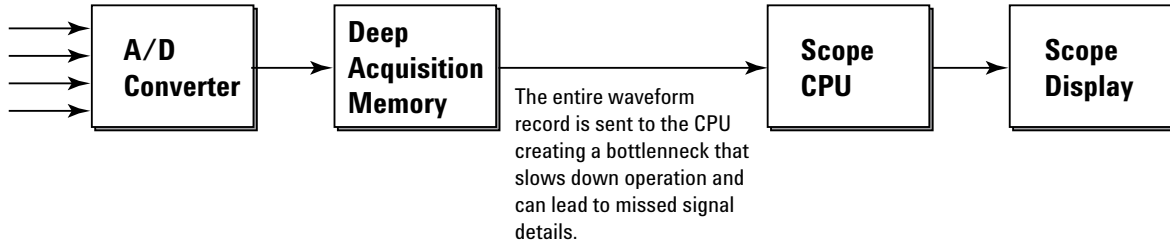

## Infiniium MegaZoom Deep-Memory Scope Architecture

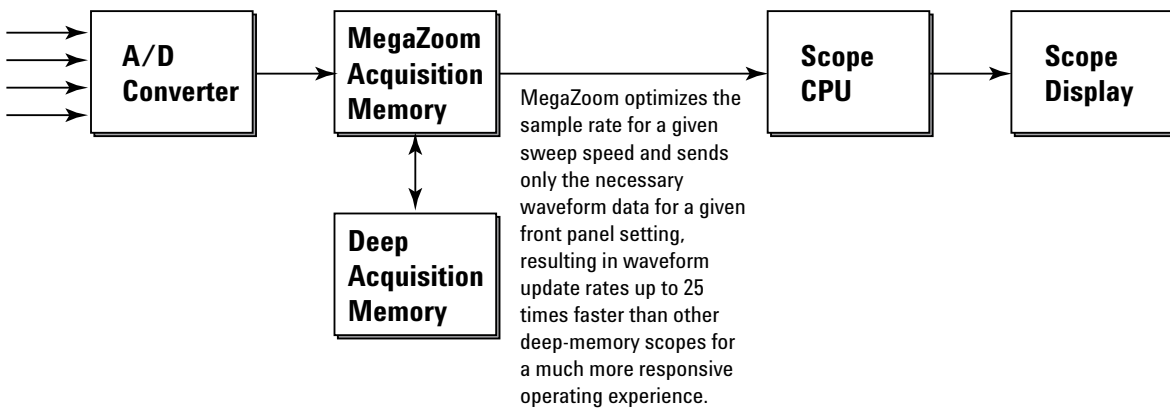

Figure 7. Agilent MegaZoom delivers fast, responsive operation through a custom, integrated circuit that optimizes data acquisition and processing.

For more information on Agilent deep-memory Infiniium oscilloscopes, go to [www.agilent.com/find/infiniium](http://www.agilent.com/find/infiniium)

### Agilent Technologies' Test and Measurement Support, Services, and Assistance

Agilent Technologies aims to maximize the value you receive, while minimizing your risk and problems. We strive to ensure that you get the test and measurement capabilities you paid for and obtain the support you need. Our extensive support resources and services can help you choose the right Agilent products for your applications and apply them successfully. Every instrument and system we sell has a global warranty. Support is available for at least five years beyond the production life of the product. Two concepts underlie Agilent's overall support policy: "Our Promise" and "Your Advantage."

#### Our Promise

Our Promise means your Agilent test and measurement equipment will meet its advertised performance and functionality. When you are choosing new equipment, we will help you with product information, including realistic performance specifications and practical recommendations from experienced test engineers. When you use Agilent equipment, we can verify that it works properly, help with product operation, and provide basic measurement assistance for the use of specified capabilities, at no extra cost upon request. Many self-help tools are available.

#### Your Advantage

Your Advantage means that Agilent offers a wide range of additional expert test and measurement services, which you can purchase according to your unique technical and business needs. Solve problems efficiently and gain a competitive edge by contracting with us for calibration, extra-cost upgrades, out-of-warranty repairs, and on-site education and training, as well as design, system integration, project management, and other professional engineering services. Experienced Agilent engineers and technicians worldwide can help you maximize your productivity, optimize the return on investment of your Agilent instruments and systems, and obtain dependable measurement accuracy for the life of those products.



### Agilent Email Updates

[www.agilent.com/find/emailupdates](http://www.agilent.com/find/emailupdates)

Get the latest information on the products and applications you select.



### Agilent Direct

[www.agilent.com/find/agilentdirect](http://www.agilent.com/find/agilentdirect)

Quickly choose and use your test equipment solutions with confidence.

### Agilent T&M Software and Connectivity

Agilent's Test and Measurement software and connectivity products, solutions and developer network allows you to take time out of connecting your instruments to your computer with tools based on PC standards, so you can focus on your tasks, not on your connections. Visit [www.agilent.com/find/connectivity](http://www.agilent.com/find/connectivity) for more information.

By internet, phone, or fax, get assistance with all your test & measurement needs

#### Online assistance:

[www.agilent.com/find/assist](http://www.agilent.com/find/assist)

#### Phone or Fax

##### United States:

(tel) 800 829 4444

##### Canada:

(tel) 877 894 4414

(fax) 905 282 6495

##### China:

(tel) 800 810 0189

(fax) 800 820 2816

##### Europe:

(tel) (31 20) 547 2323

(fax) (31 20) 547 2390

##### Japan:

(tel) (81) 426 56 7832

(fax) (81) 426 56 7840

##### Korea:

(tel) (82 2) 2004 5004

(fax) (82 2) 2004 5115

##### Latin America:

(tel) (305) 269 7500

(fax) (305) 269 7599

##### Taiwan:

(tel) 0800 047 866

(fax) 0800 286 331

##### Other Asia Pacific Countries:

(tel) (65) 6375 8100

(fax) (65) 6836 0252

Email: [tm\\_asia@agilent.com](mailto:tm_asia@agilent.com)

Product specifications and descriptions in this document subject to change without notice.

© Agilent Technologies, Inc. 2004

Printed in USA

May 25, 2004

5988-5655EN

